

HF-SERIES

Hand Feed Scales

Model HF-1
(2 operator
model)



**Product is fed by hand
into the weigh bucket**

Difficult Product Net Weigh FILLER

Fast. Accurate. Reliable.

*Easy-to-use, 100% accurate,
versatile to almost any solid
piece product.*

- ◆ For food and non-food applications
- ◆ Single and Dual head Designs
- ◆ Fill by Count or Weight
- ◆ Every fill within Tolerance
- ◆ Off-the-Shelf components
- ◆ Interface with a bagger or index conveyor

**Featuring
touch screen
controller
with
multiple
menus
for ease-of-use
and optimum control.**



WEIGH RIGHT
Automatic Scale Co.

800-571-0249

www.weighright.com

10 Benefits of using an HF Scale

1. Low Cost
2. 100% Accurate
3. Quick Changeover
4. Easy to Clean
5. Easy to Maintain
6. Easy to Use
7. Product Versatility
8. Interface with a bagger or conveyor.
9. Product Quality Control
(operator can discard bad product)
10. Gentle Handling

HF Scales package the difficult products



Common Difficult Products Packaged on an HF Scale:

Hardware - Pet Treats - Wrapped Candies - Plastic Parts
IQF foods, (bulky non-free flowing products). *Ideal for customers who package a lot of short-runs of different products requiring quick change-over and / or filling into multiple packages (bags, cartons, cups, jars, boxes).*

3 WAYS TO USE YOUR HF SCALE



2 OPERATORS

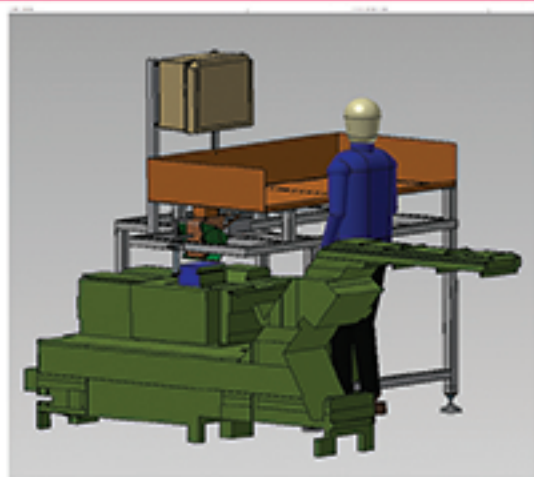

OPERATOR WITH A
BAGGER

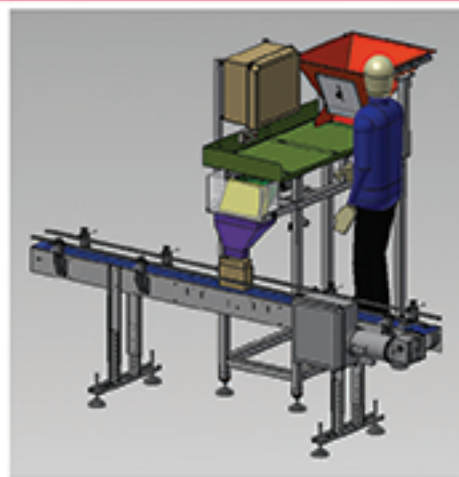

OPERATOR WITH A
CONVEYOR



WEIGH RIGHT
Automatic Scale Co.

612-A Mills Rd. Joliet, IL 60433
Ph: 815-726-4626 Fax: 815-726-7638
800-571-0249 www.weighright.com

FILL RATES

2 Operators:
Up to 15 fills per minute.*

Interfaced with bagger or conveyor:
Up to 20 fills per minute.*

*Subject to operator skill, fill weight,
and capacity of receiving equipment.